



The Micro Flowmeter can measure low flow liquids. It is far less costly than other positive displacement flowmeters, fluid meters and liquid measuring instruments capable of measuring low flow rates.

It is less susceptible to wear and more capable of service in hostile liquids. It can easily be disassembled, cleaned and reassembled with reasonable care in the field.



- Flow Range:**  $\text{ØT VD4:}$  .015 to 4.00 GPH (1 to 250 cc/min. or 0.02 cc/cycle)  
 $\text{ØT TD20A:}$  .075 to 20.00 GPH (5 to 1250 cc/min. or 0.10 cc/cycle)
- Accuracy:**  $\pm .1\%$
- Repeatability:** +/- 0.1%
- Maximum Operating Pressure:** **Standard:** 3,000 psig (207 bar)  
**High Pressure:** 21,000 psig (1448 bar)
- Maximum Differential Pressure:** 0250: 5 psi  
1250: 15 psi
- Temperature Range:** -40° to 180° F (-40° to 80° C)
- Maximum Viscosity:** 100 SSU (25 cp)

**NUTATING OPERATING PRINCIPLE**

Measurement occurs as the result of the dual orbiting motion of the nutating mechanism as it rolls on the beam. Refer to figures A, B, C and D in sequence. This motion is induced by the fluid as it passes through the meter. This motion is consistent because the differential pressure forces are always great enough to ensure that the nutating mechanism travels the complete volume in each chamber. The process repeats itself 12 to 250 cycles per second, in proportion to the fluid flow through the meter. A flow signal is produced by interrupting the light from a photo-emitting/detecting device. The interruptions are created by a magnet wire which tracks the magnet encapsulated in the orbiting nutating mechanism. The interruptions are then converted to an electronic square wave output, which is used to quantify the flow.

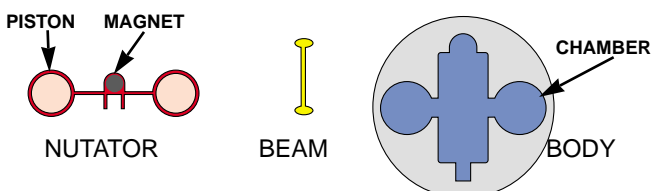
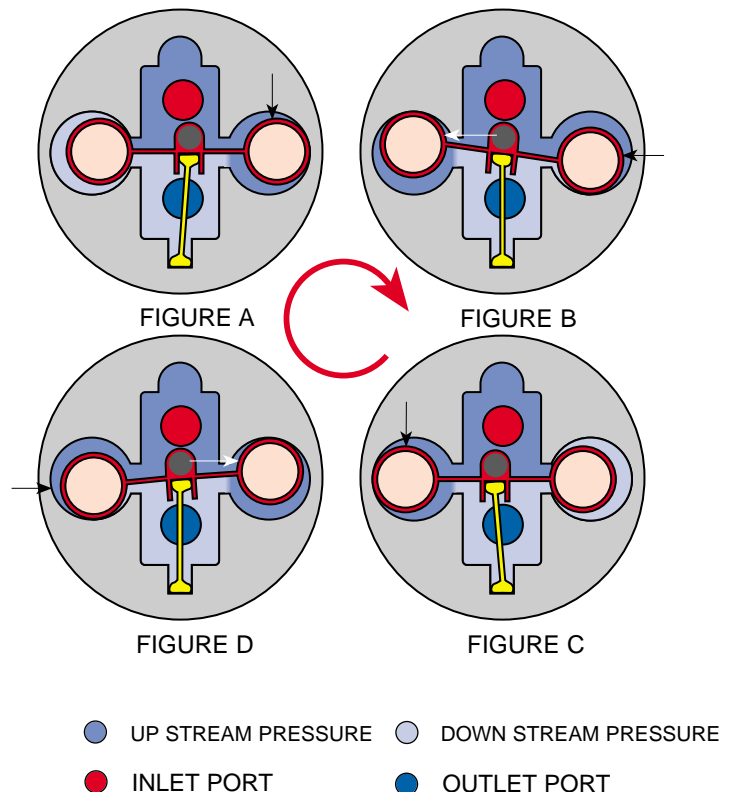

## FLOWMETER FEATURES

- The relative simplicity of the MICRO FLOWMETER makes it far less costly than other positive displacement flowmeters which may be capable of measuring similar low flow rates.
- Compared to other positive displacement flowmeters, the MICRO FLOWMETER is less susceptible to wear. The reasons for this are as follow:
  - The parts are so small that the relative velocities amongst the moving parts are quite low.
  - All forces acting on one side of the nutator are largely offset by opposing forces acting on the opposite side.
  - The ends of the beam are rounded resulting in a rolling motion rather than sliding during operation.
- Since the moving parts are not rigidly attached to each other or the motion detection mechanism, the MICRO FLOWMETER is capable of service in fluids less filtered than other devices which may be capable of measuring similar low flow rates.
- Should the MICRO FLOWMETER become clogged with debris, it can be easily disassembled, cleaned and reassembled with reasonable care in the field.

## TD SERIES SPECIFICATIONS

- All materials in contact with the fluid media are 316 stainless steel and PTFE.

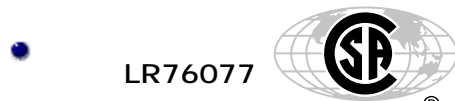

LR76077

Explosion Proof, Class I, Division 1, Groups C & D Certified By Canadian Standards Association.

INTRINSICALLY SAFE Certification by CSA (Added Cost Option "IS").

- **Ranges:**  
FMTD4: <.015-4.00 GPH [1-250 ccpm]  
FMTD20: <.075 -20.00 GPH [5 - 1250 ccpm]
- **Accuracy:**  
+/- 1% of scale
- **Repeatability:**  
+/- 0.1%
- **Output Signal:**  
0 - 5 Volt Square Wave
- **Maximum Operating Pressure:**  
3,000 psig [21 MPa] Standard  
21,000psi [147 MPa] Added Cost Option "P"
- **Max.  $\Delta$  P:** 5 psi [34kPa] FMTD4  
15 psi [102kPa] FMTD20
- **Dimensions:** 2.50" D. X  
4.63 " L. [6.4 cm D. X 11.8 cm L.]
- **Viscosity:** 100 SSU [25 cp] Maximum Recommended. Higher Viscosities Reduce Low Flow Rate Capabilities.
- **Displacement:**  
FMTD4: Approximately 50 pulses per cc  
FMTD20: Approximately 10 pulses per cc
- **Temp. Range:**  
-40 To +180° F [-40 To +80°]
- **Power:**  
8 - 30 VDC, 50 milliamps maximum
- **Power/Signal Cable:**  
3 Feet [1 Meter] Long
- **Process Connections:**  
1/4"NPT
- **Conduit Connection:**  
1/2" NPT
- **Weight:**  
[1.32 Kg.]

# CONSTRUCTION

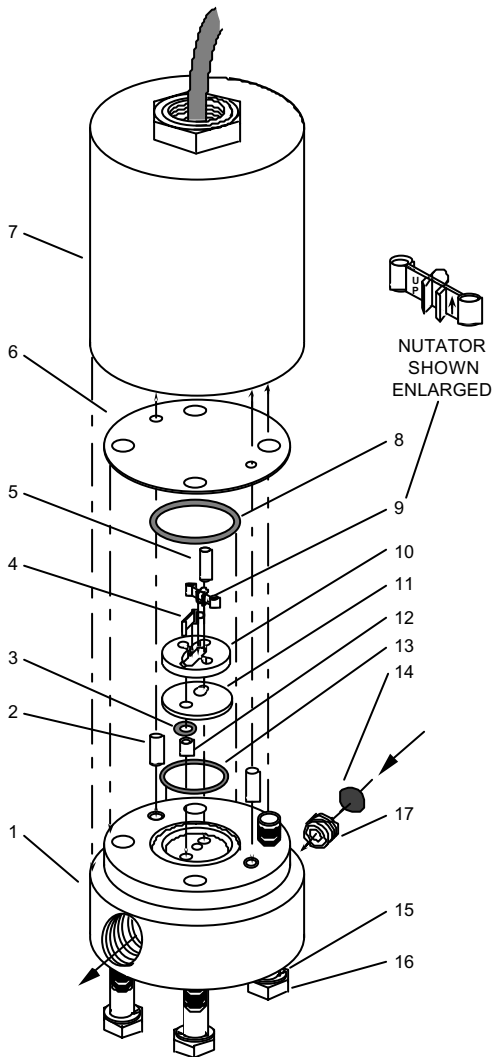

FMTD4 PARTS LIST				
ITEM NO.	PART NUMBER	DESCRIPTION	MATERIAL	QTY.
1	570618	PORT HOUSING	316 SS	1
2	570003-10	DOWEL PIN	18-8 SS	2
3	570001-T006	"O" RING	TFE	1
4	570418	BEAM	316 SS	1
5	570310	DOWEL PIN	316 SS	1
6	570943	DIAPHRAGM	316 SS	1
7*	570809	ELECTRONICS ASS'Y		1
8	570001-T118	"O" RING	TFE	1
9	570122	NUTATOR	316 SS	1
10	570521	BODY	316 SS	1
11	570945	BALANCE PLATE	316 SS	1
12	570930	OUTLET BUSHING	316 SS	1
13	570001-T017	"O" RING	TFE	1
14	570307	SCREEN	316 SS	1
15	570003-20	LOCK WASHER	18-8 SS	4
16	570002-10	CAP SCREW	18-8 SS	4

FMTD20 PARTS LIST				
ITEM NO.	PART NUMBER	DESCRIPTION	MATERIAL	QTY.
9	570123	NUTATOR	316 SS	1
10	570522	BODY	316 SS	1

ALL OTHER ITEMS SAME AS FMTD4

INJECTION PUMP MODIFICATIONS [-O]				
ITEM NO.	PART NUMBER	DESCRIPTION	MATERIAL	QTY.
17	570941-08	FMTD4 ORIFICE	316 SS	1
17	570941-18	FMTD20 ORIFICE	316 SS	1

ALL OTHER ITEMS SAME AS ABOVE

\* THIS ASSEMBLY IS NOT FIELD SERVICEABLE. CONSULT FACTORY FOR SERVICE.

## MECHANICAL INSTALLATION AND OPERATING CONSIDERATIONS

1. Once installed and ready to operate, open the bypass and bleed valves wide before slowly starting fluid flow to the Micro flowmeter. Allow the bleed valve to remain open until air and vapors which may have been trapped in the Micro flowmeter have been "bled". If air and vapors are persistent, turn the Micro flowmeter upside down [compression fittings would be useful] while it is running for a short time and then return to upright position. Close the the bleed and bypass valves and begin normal system operation. [The depicted recommended installation is for systems operating with pressures greater than 20 psi. The bypass and bleed arrangement can safely be omitted from systems operating at lower pressures].

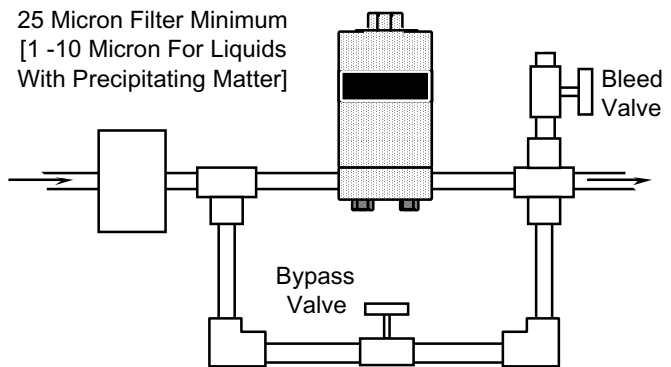

### RECOMMENDED INSTALLATION

2. If the Micro flowmeter is subject to hydraulic pulsations, check valves may be required.
3. If it is necessary to disassemble the mechanical portion for cleaning or other reason, ascertain that the nutator is installed with the inscribed arrow pointing up [toward the electronic assembly]. Failure to do so may result in loss of alignment of the motion detection mechanism. Use 4 - 5 foot pounds of torque on the cap screws when reassembling.

# ELECTRONIC INSTALLATION AND OPERATING CONSIDERATIONS

1. A twisted, shielded, 18 gauge, 3 or more conductor cable is recommended to minimize interference. If the Micro flowmeter signal at the electronics is less than required, use a larger gauge wire. If this does not effect the desired result, a repeater may be required. The two ground terminals should be jumpered at the electronics. Power and signal wires should be shielded. Only one end of the shield should be connected to ground. [Never use the shield as a signal or power conductor.]

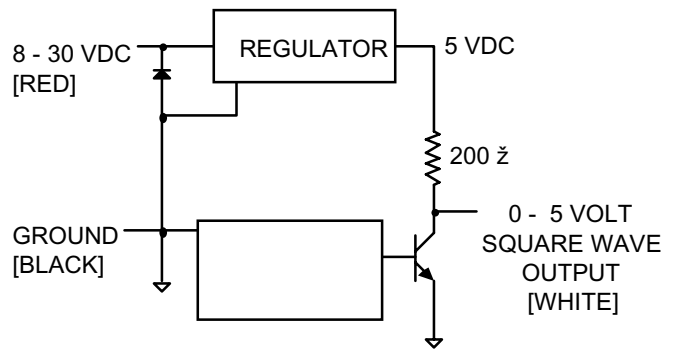

**ELECTRONIC FUNCTIONAL DIAGRAM**

2. When using inductive devices such as relays, motors, or solenoids, care must be taken to avoid voltage transients which result when these devices are switched on and off. These transients can often be strong enough to interfere with [and even damage] system electronics. If the inductive devices are DC, a suppression diode should be placed across the coil as shown in [Figure 1](#).

On AC systems, a type of transient suppression device called a Varistor [MOV] should be used. The power should be controlled by a solid state relay which switches at zero voltage. The power supply driving the inductive devices should not be used to drive the system electronics. The supply for the electronics should have an AC line filter either integral with the supply or as a separate module. It is strongly recommended that wires which control the inductive devices not be bundled over long distances with sensor signal wires, even if these wires are shielded.

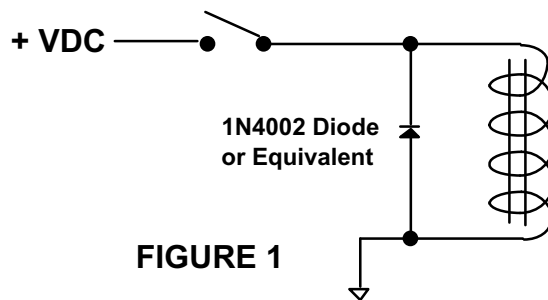

**FIGURE 1**

A full range of Rate/Totalizers, monitors and batch controllers are available, suitable for safe area or hazardous area applications. For wiring diagrams, recommended barriers etc, consult your supplier.

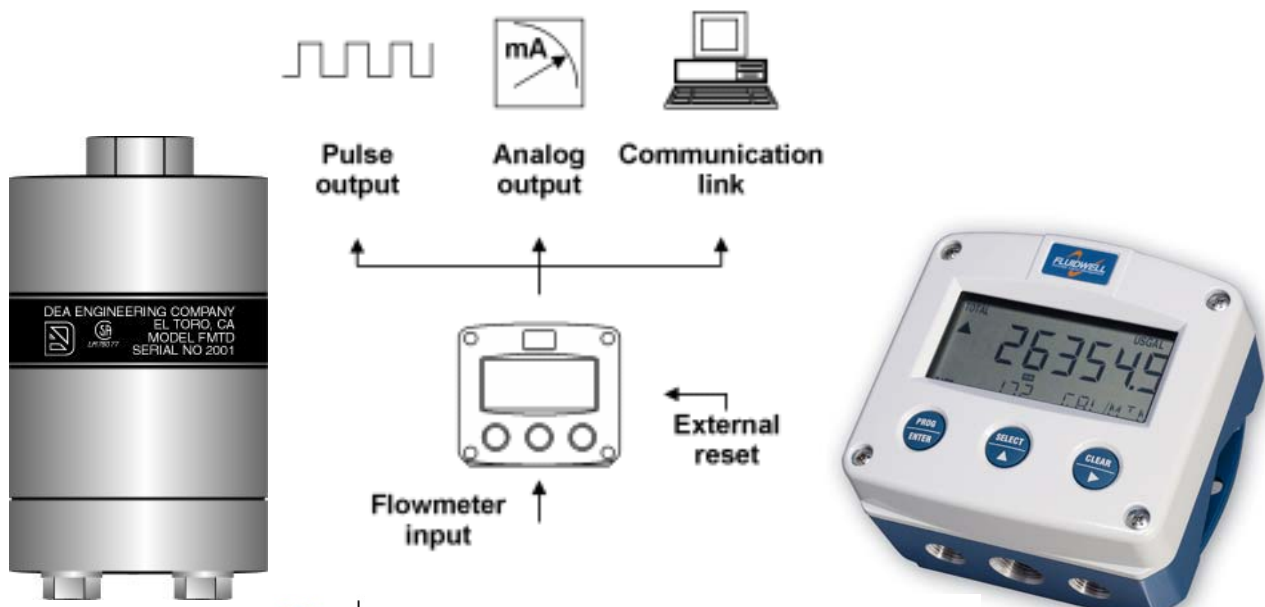

**PROFLOW**  
D Y N A M I C S

330 S. Maple St. Unit F & G  
Corona, Ca. 92880 USA  
Office: (951) 279-5500 Fax: (951) 279-5525  
Website: www.proflowdynamics.com